

TYPE - NS/H HORIZONTAL

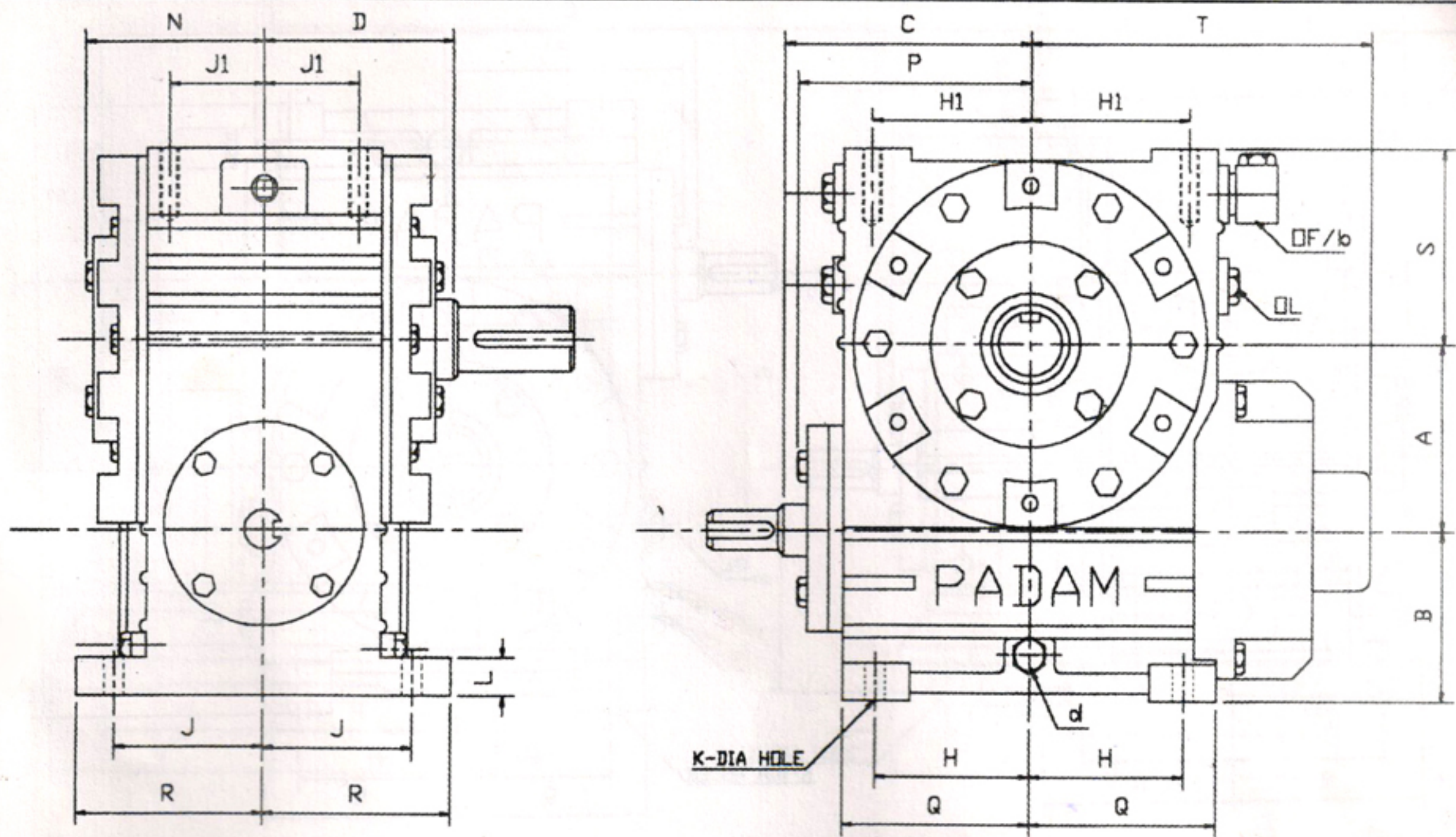

SHAFT HANDLING

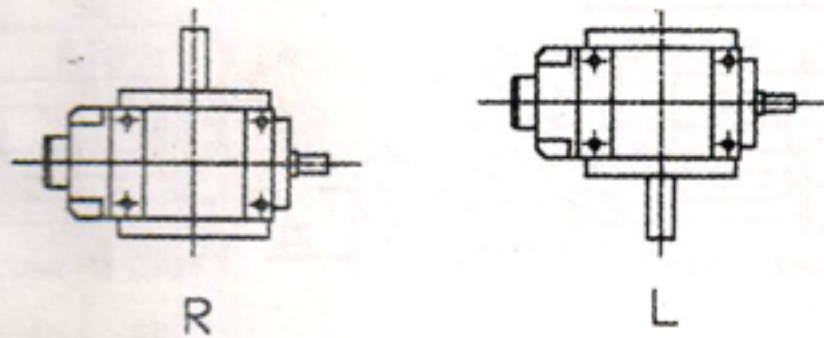

SHAFT DETAIL

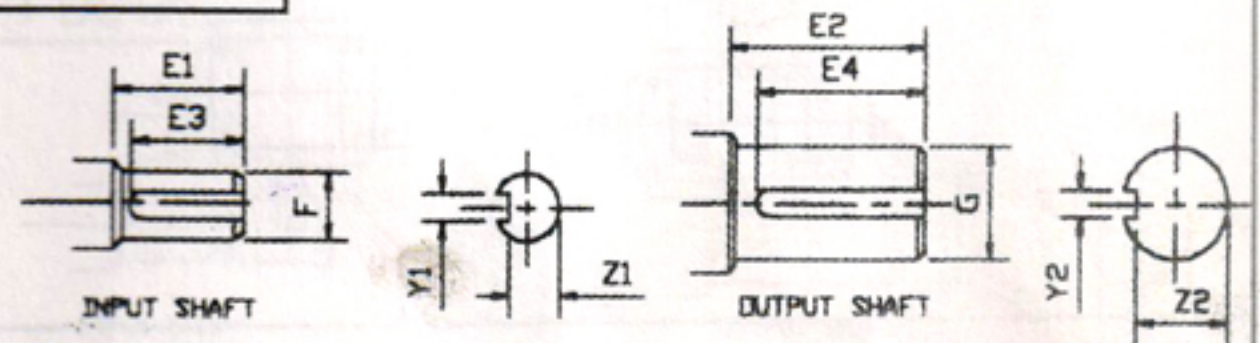

Size	A	B	C	D	H	H1	J	J1	K	L	N	P	Q	R	S	T
2"	2"	57	94	70	54	54	58	35	11	14	68	90	70	75	80	145
2.5"	2.5"	63	108	84	64	72	67	40	11	14	78	104	85	80	92	162
3"	3"	86	128	95	80	82	77	48	11	18	90	120	98	90	105	190
3.5"	3.5"	86	140	108	91	91	84	54	14	20	98	130	110	100	115	200
4"	4"	108	164	128	108	115	102	65	18	22	120	158	136	120	130	240
5"	5"	114	190	148	124	131	111	75	18	26	130	185	158	136	150	272
6"	6"	127	205	165	133	140	121	85	22	30	140	195	170	150	185	295

SHAFT DIMENSIONS

Size	E1	E2	E3	E4	F	G	Y1	Y2	Z1	Z2
2"	44	54	40	50	18	23	5	6	15	20
2.5"	50	56	45	52	23	27	6	8	20	23
3"	56	68	52	63	27	33	6	10	24	29
3.5"	56	78	52	73	27	38	6	10	24	34
4"	65	90	60	85	32	45	8	12	28	40
5"	70	102	65	98	38	55	10	16	34	49
6"	74	110	70	105	38	60	10	16	34	54