

TYPE - NS/H MOTORISED HORIZONTAL

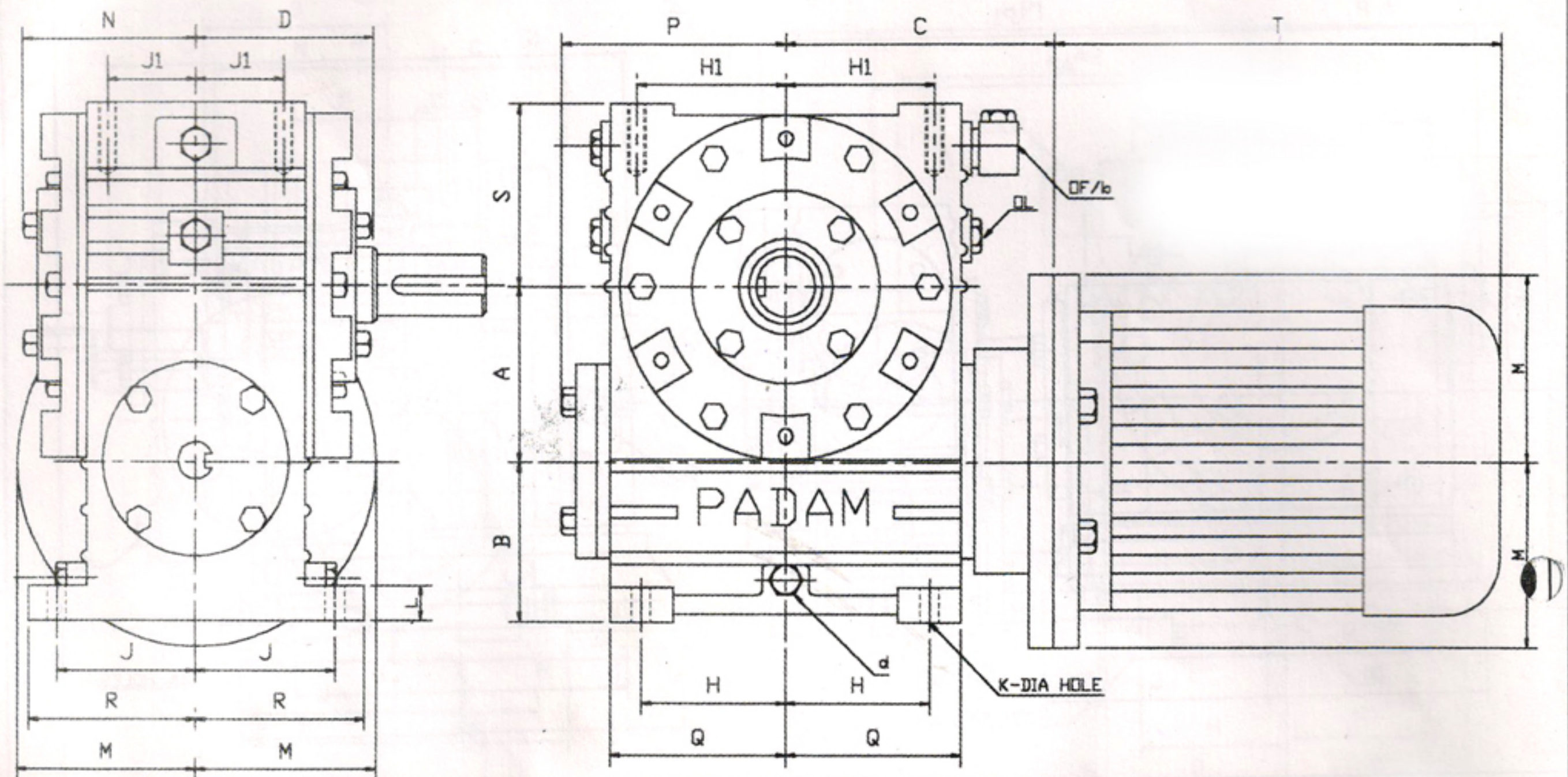

SHAFT HANDLING

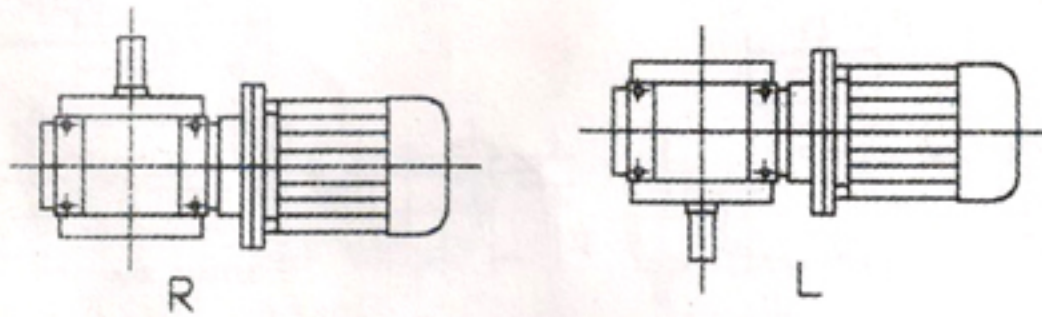

SHAFT DETAIL

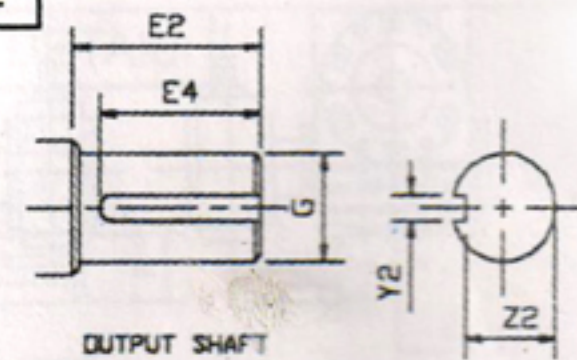

Size	A	B	C	D	H	H1	J	J1	K	L	M	N	P	Q	R	S	T
2"	2"	57	120	70	54	54	58	35	11	14	100	68	90	70	75	80	240
2.5"	2.5"	63	140	84	64	72	67	40	11	14	100	78	104	85	80	92	240
3"	3"	86	155	95	80	82	77	48	11	18	125	90	120	98	90	105	300
3.5"	3.5"	86	145	108	91	91	84	54	14	20	125	98	130	110	100	115	300
4"	4"	108	165	128	108	115	102	65	18	22	125	120	158	136	120	130	320
5"	5"	114	190	148	124	131	111	75	18	26	150	130	185	158	136	150	320
6"	6"	127	205	165	133	140	121	85	22	30	150	140	195	170	150	185	360

SHAFT DIMENSIONS

Size	E2	E4	G	Y2	Z2
2"	54	50	23	6	20
2.5"	56	52	27	8	23
3"	68	63	33	10	29
3.5"	78	73	38	10	34
4"	90	85	45	12	40
5"	102	98	55	16	49
6"	110	105	60	16	54