

TYPE - NS/DV DOUBLE VERTICAL

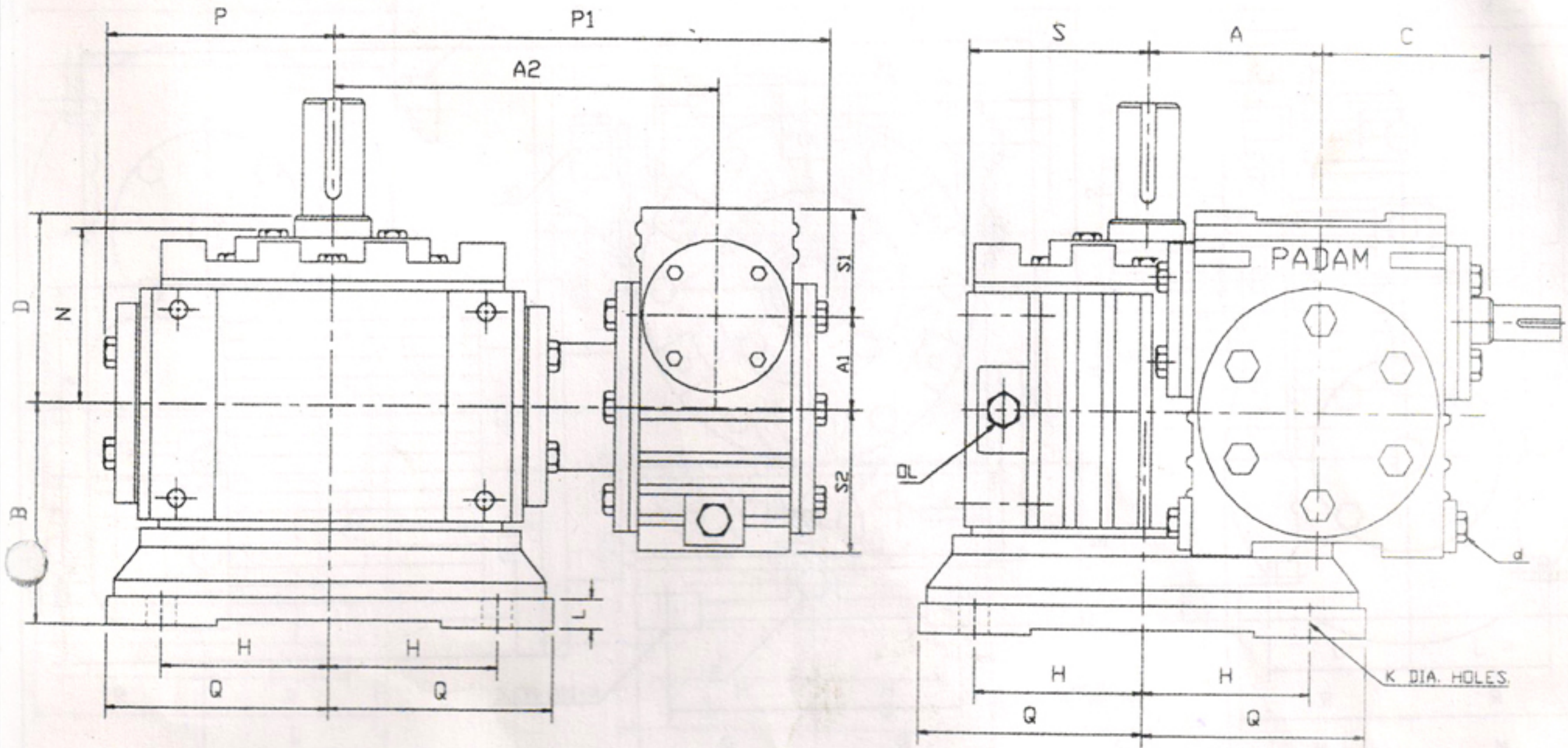

SHAFT HANDLING

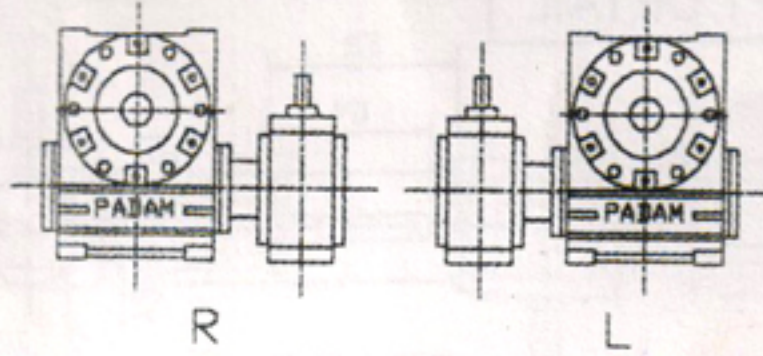

SHAFT DETAIL

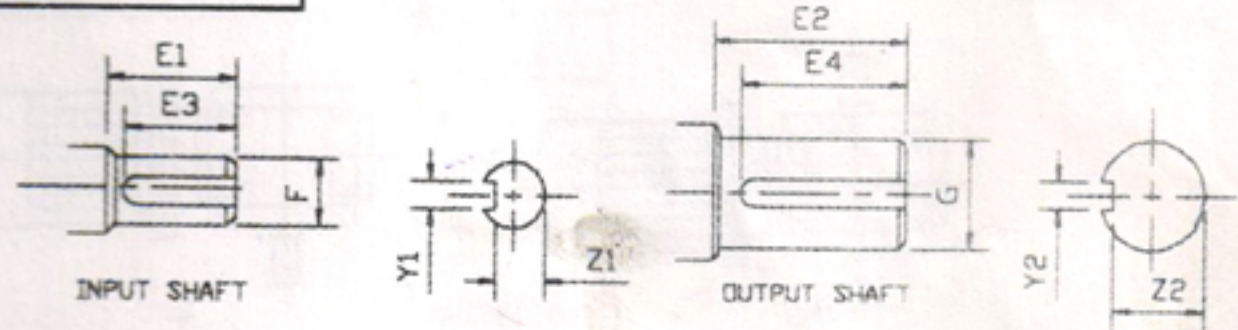

Size	A	A1	A2	B	C	D	H	K	L	N	P	P1	Q	S	S1	S2
2"	2"	2"	165	90	94	70	64	11	14	68	90	225	80	80	57	80
2.5"	2.5"	2"	180	98	94	84	75	11	14	78	104	240	90	92	57	80
3"	3"	2"	195	115	94	95	100	11	18	90	120	255	118	105	57	80
3.5"	3.5"	2"	205	120	94	108	105	14	20	98	130	265	124	115	57	80
4"	4"	2.5"	245	144	108	128	114	18	22	120	158	315	140	130	63	92
5"	5"	3"	285	172	128	148	140	18	26	130	185	365	160	150	86	105
6"	6"	4"	325	172	164	165	152	22	30	140	195	435	178	185	108	130

SHAFT DIMENSIONS

Size	E1	E2	E3	E4	F	G	Y1	Y2	Z1	Z2
2"	44	54	40	50	18	23	5	6	15	20
2.5"	44	56	40	52	18	27	5	8	15	23
3"	44	68	40	63	18	33	5	10	15	29
3.5"	44	78	40	73	18	38	5	10	15	34
4"	50	90	45	85	23	45	6	12	20	40
5"	56	102	52	98	27	55	6	16	24	49
6"	65	110	60	105	32	60	8	16	28	54