

# TYPE - NS/D DOUBLE REDUCTION

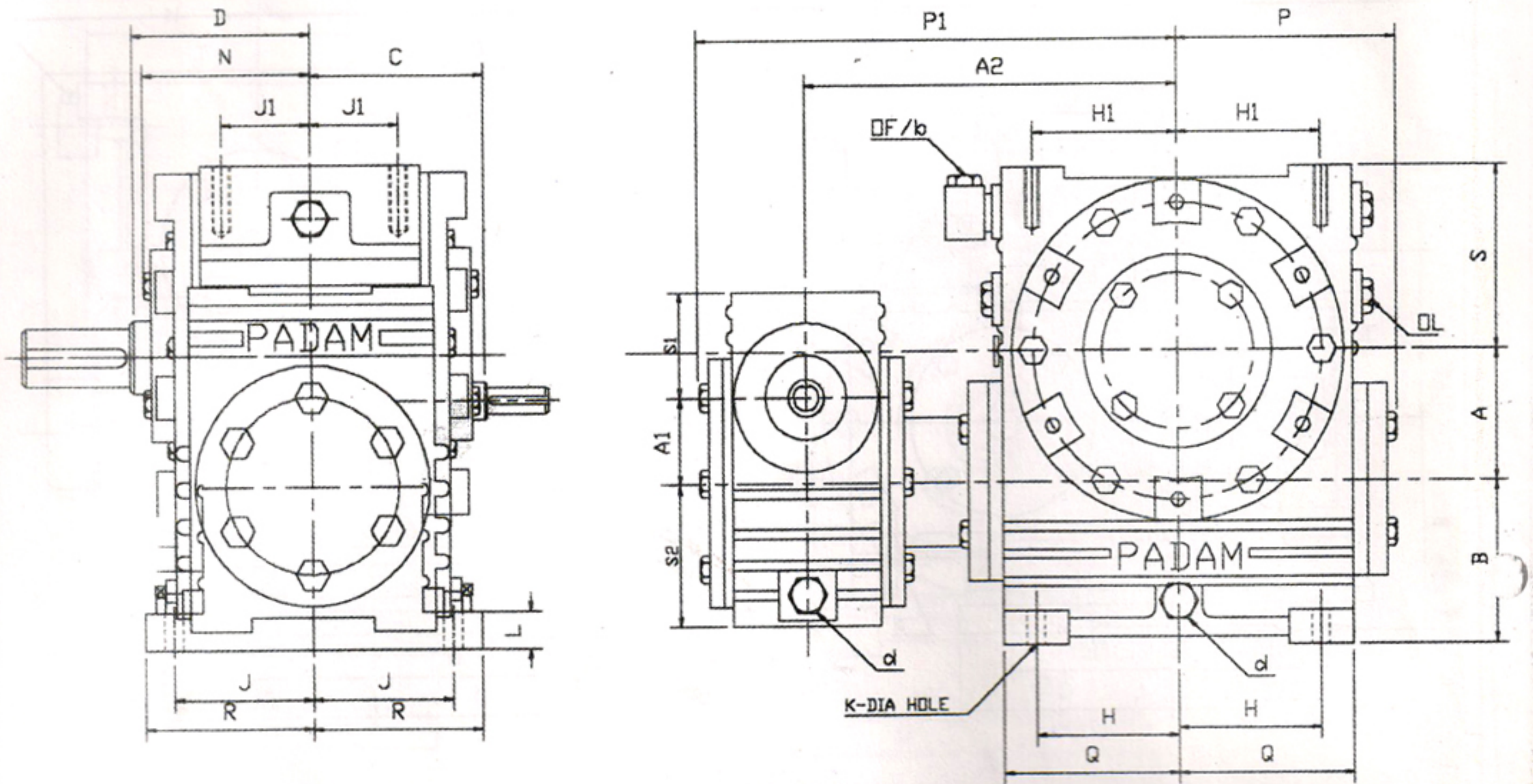

## SHAFT HANDLING

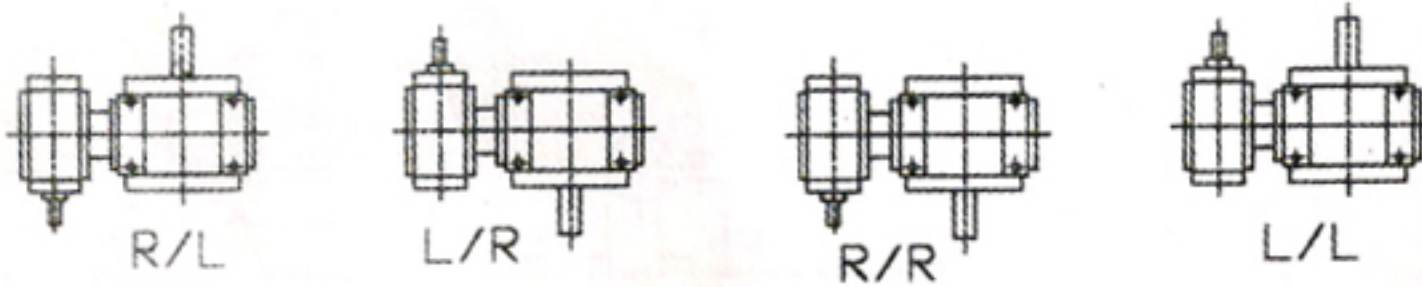

## SHAFT DETAIL

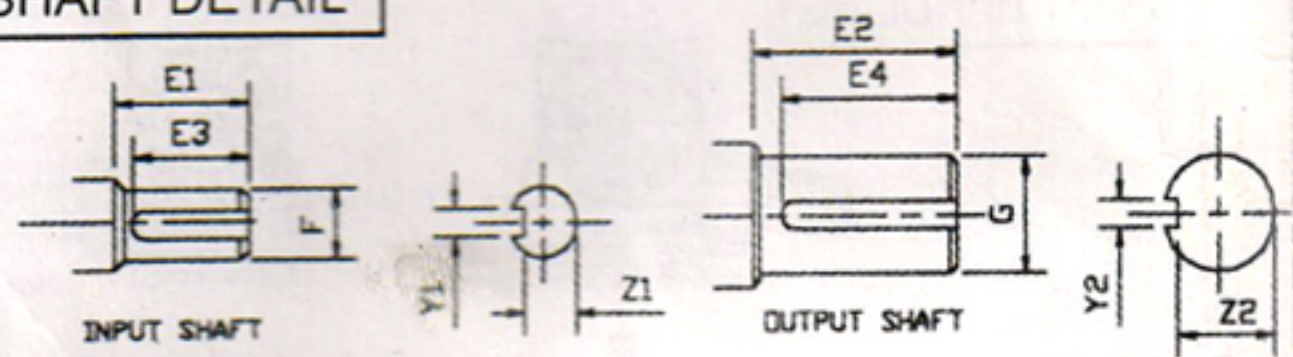

Size	A	A1	A2	B	C	D	H	H1	J	J1	K	L	N	P	P1	Q	R	S	S1	S2
2"	2"	2"	165	57	94	70	54	54	58	35	11	14	68	90	225	70	75	80	57	80
2.5"	2.5"	2"	180	63	94	84	64	72	67	40	11	14	78	104	240	85	80	92	57	80
3"	3"	2"	195	86	94	95	80	82	77	48	11	18	90	120	255	98	90	105	57	80
3.5"	3.5"	2"	205	86	94	108	91	91	84	54	14	20	98	130	265	110	100	115	57	80
4"	4"	2.5"	245	108	108	128	108	115	102	65	18	22	120	158	315	136	120	130	63	92
5"	5"	3"	285	114	128	148	124	131	111	75	18	26	130	185	365	158	136	150	86	105
6"	6"	4"	325	127	164	165	133	140	121	85	22	30	140	195	435	170	150	185	108	130

## SHAFT DIMENSIONS

Size	E1	E2	E3	E4	F	G	Y1	Y2	Z1	Z2
2"	44	54	40	50	18	23	5	6	15	20
2.5"	44	56	40	52	18	27	5	8	15	23
3"	44	68	40	63	18	33	5	10	15	29
3.5"	44	78	40	73	18	38	5	10	15	34
4"	50	90	45	85	23	45	6	12	20	40
5"	56	102	52	98	27	55	6	16	24	49
6"	65	110	60	105	32	60	8	16	28	54